

High Quality Diamond
THINWHEELS™



719-481-4205 • fax 719-488-0872 • sales@diacut.com • www.diacut.com

A LEADING MANUFACTURER OF **DIAMOND BLADES**



P.O. Box 217, 773 Hwy. 105, Palmer Lake, CO 80133
 phone: **719-481-4205** fax: 719-488-0872
 email: **sales@diacut.com** web: www.diacut.com



3" DIAMETER SERIES

METAL BOND Diamond
 Slotting • Slicing • Dicing • Cut-off

OUTSIDE DIAMETER: 3" INSIDE DIAMETER: 1.75"

➤ **Maximum grit size for the 1A8 Metal Bond wheels is 325/400 mesh or finer.**
 ROUGHER GRIT SIZES MAY BE AVAILABLE UPON REQUEST,
 BUT THE THICKNESS TOLERANCE MAY VARY AS A RESULT.

Thinwheels available in thickness from .007"-.250"
 in increments of .001" or a fraction thereof.

3 PIECE MINIMUM ORDER

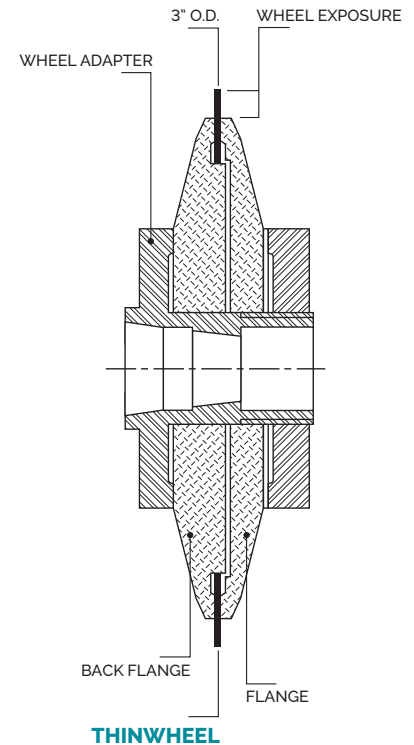

SUPERABRASIVE SOLID TO HOLE

WHEEL THICKNESS	THICKNESS TOLERANCE	DIAMOND
.007"-.009"	+0/-0.0004"	\$ 209.00
.010"-.025"	+0/-0.0004"	\$ 174.00
.026"-.050"	+0/-0.0004"	\$ 197.00
.051"-.075"	+0/-0.0004"	\$ 218.00
.076"-.100"	+0/-0.0004"	\$ 241.00
.101"-.125"	+0/-0.0004"	\$ 259.00
.126"-.150"	+0/-0.0004"	\$ 277.00
.151"-.175"	+0/-0.0004"	\$ 294.00
.176"-.200"	+0/-0.0004"	\$ 311.00
.201"-.225"	+0/-0.0004"	\$ 325.00
.226"-.250"	+0/-0.0004"	\$ 335.00

PRICES SUBJECT TO CHANGE WITHOUT NOTICE.
 PRICES EFFECTIVE SEPT. 2024
 VISA/MASTERCARD ACCEPTED

1A8 FLANGES FOR 3" THINWHEEL

A special Diacut flange must be used with the 3" Thinwheel.

PART NO.	DIAMETER	WHEEL EXPOSURE	PRICE
F1A8-385	2.85"	.075"	\$ 79
F1A8-370	2.70"	.150"	\$ 77
F1A8-355	2.55"	.225"	\$ 75
F1A8-340*	2.40"	.300"	\$ 74
F1A8-325*	2.25"	.375"	\$ 73
FS300	Complete set of flanges		\$360

Flange thickness for 3" Thinwheel is .400"
 Standard hole size for all flanges is 1.25"
 Special hole size- add \$10

WHEEL EXPOSURE NOT TO EXCEED 15 TIMES THE THICKNESS OF THE BLADE

WHEEL ADAPTERS

Keep grinding wheels mounted for longer wheel life and less dressing time.



WA200-1LH Wheel adapter O.D. 2-1/4" \$80
 *WAX200-1LH Wheel adapter O.D. 1-3/4" \$165



P.O. Box 217, 773 Hwy. 105, Palmer Lake, CO 80133
 phone: **719-481-4205** fax: 719-488-0872
 email: **sales@diacut.com** web: www.diacut.com



4" DIAMETER SERIES

METAL BOND Diamond
 Slotting • Slicing • Dicing • Cut-off

OUTSIDE DIAMETER: 4" INSIDE DIAMETER: 2.75"

➤ **Maximum grit size for the 1A8 Metal Bond wheels is 325/400 mesh or finer.**
 ROUGHER GRIT SIZES MAY BE AVAILABLE UPON REQUEST,
 BUT THE THICKNESS TOLERANCE MAY VARY AS A RESULT.

Thinwheels available in thickness from .007"-.250"
 in increments of .001" or a fraction thereof.

3 PIECE MINIMUM ORDER

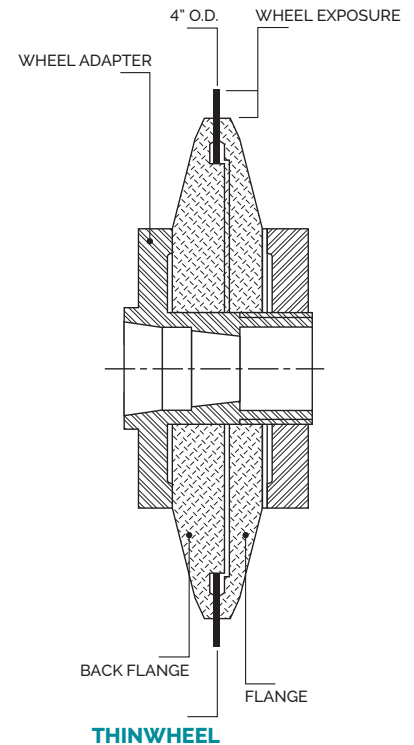

THINWHEEL

SUPERABRASIVE SOLID TO HOLE

WHEEL THICKNESS	THICKNESS TOLERANCE	DIAMOND
.007"-.009"	+0/-0.0004"	\$ 215.00
.010"-.025"	+0/-0.0004"	\$ 187.00
.026"-.050"	+0/-0.0004"	\$ 216.00
.051"-.075"	+0/-0.0004"	\$ 244.00
.076"-.100"	+0/-0.0004"	\$ 268.00
.101"-.125"	+0/-0.0004"	\$ 288.00
.126"-.150"	+0/-0.0004"	\$ 307.00
.151"-.175"	+0/-0.0004"	\$ 322.00
.176"-.200"	+0/-0.0004"	\$ 333.00
.201"-.225"	+0/-0.0004"	\$ 343.00
.226"-.250"	+0/-0.0004"	\$ 350.00

PRICES SUBJECT TO CHANGE WITHOUT NOTICE.
 PRICES EFFECTIVE SEPT. 2024
 VISA/MASTERCARD ACCEPTED

1A8 FLANGES FOR 4" THINWHEEL

A special Diacut flange must be used with the 4" Thinwheel.

PART NO.	DIAMETER	WHEEL EXPOSURE	PRICE
F1A8-485	3.85"	.075"	\$ 99
F1A8-470	3.70"	.150"	\$ 98
F1A8-455	3.55"	.225"	\$ 97
F1A8-440	3.40"	.300"	\$ 96
F1A8-425	3.25"	.375"	\$ 95
FS400	Complete set of flanges		\$470

Flange thickness for 4" Thinwheel is .650"
 Standard hole size for all flanges is 1.25"
 Special hole size- add \$10

WHEEL EXPOSURE NOT TO EXCEED 15 TIMES THE THICKNESS OF THE BLADE

WHEEL ADAPTERS

Keep grinding wheels mounted for longer wheel life and less dressing time.



WA200-1LH Wheel adapter O.D. 2-1/4" \$80



P.O. Box 217, 773 Hwy. 105, Palmer Lake, CO 80133
 phone: **719-481-4205** fax: 719-488-0872
 email: **sales@diacut.com** web: www.diacut.com



5" DIAMETER SERIES

METAL BOND Diamond
 Slotting • Slicing • Dicing • Cut-off

OUTSIDE DIAMETER: 5" INSIDE DIAMETER: 3.5"

➤ **Maximum grit size for the 1A8 Metal Bond wheels is 325/400 mesh or finer.**
 ROUGHER GRIT SIZES MAY BE AVAILABLE UPON REQUEST,
 BUT THE THICKNESS TOLERANCE MAY VARY AS A RESULT.

Thinwheels available in thickness from .007"-.250"
 in increments of .001" or a fraction thereof.

3 PIECE MINIMUM ORDER

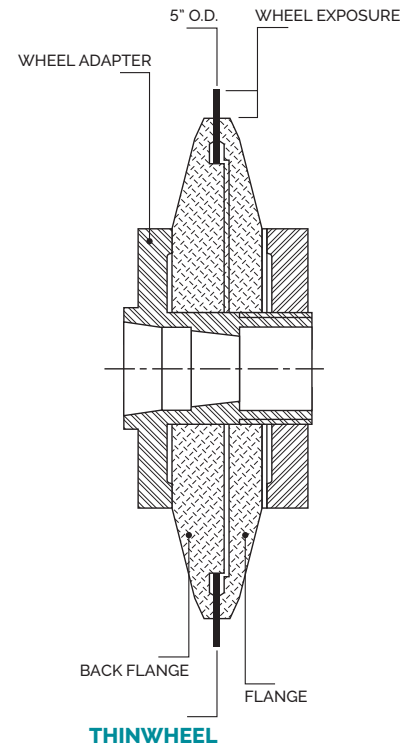

SUPERABRASIVE SOLID TO HOLE

WHEEL THICKNESS	THICKNESS TOLERANCE	DIAMOND
.010"-.025"	+0/-0.0004"	\$ 205.00
.026"-.050"	+0/-0.0004"	\$ 248.00
.051"-.075"	+0/-0.0004"	\$ 288.00
.076"-.100"	+0/-0.0004"	\$ 322.00
.101"-.125"	+0/-0.0004"	\$ 335.00
.126"-.150"	+0/-0.0004"	\$ 378.00
.151"-.175"	+0/-0.0004"	\$ 396.00
.176"-.200"	+0/-0.0004"	\$ 414.00
.201"-.225"	+0/-0.0004"	\$ 427.00
.226"-.250"	+0/-0.0004"	\$ 432.00

1A8 FLANGES FOR 5" THINWHEEL

A special Diacut flange must be used with the 5" Thinwheel.

PART NO.	DIAMETER	WHEEL EXPOSURE	PRICE
F1A8-575	4.75"	.125"	\$113
F1A8-560	4.60"	.200"	\$108
F1A8-545	4.45"	.275"	\$106
F1A8-530	4.30"	.350"	\$104
F1A8-515	4.15"	.425"	\$99
F1A8-500	4.00"	.500"	\$97
FS500	Complete set of flanges		\$580

Flange thickness for 5" Thinwheel is .650"
 Standard hole size for all flanges is 1.25"
 Special hole size- add \$10
WHEEL EXPOSURE NOT TO EXCEED 15 TIMES THE THICKNESS OF THE BLADE

WHEEL ADAPTERS

Keep grinding wheels mounted for longer wheel life and less dressing time.



WA200-1LH Wheel adapter O.D. 2-1/4" \$80

PRICES SUBJECT TO CHANGE WITHOUT NOTICE.
 PRICES EFFECTIVE SEPT. 2024
 VISA/MASTERCARD ACCEPTED



P.O. Box 217, 773 Hwy. 105, Palmer Lake, CO 80133
 phone: **719-481-4205** fax: 719-488-0872
 email: **sales@diacut.com** web: www.diacut.com



6" DIAMETER SERIES

METAL BOND Diamond
 Slotting • Slicing • Dicing • Cut-off

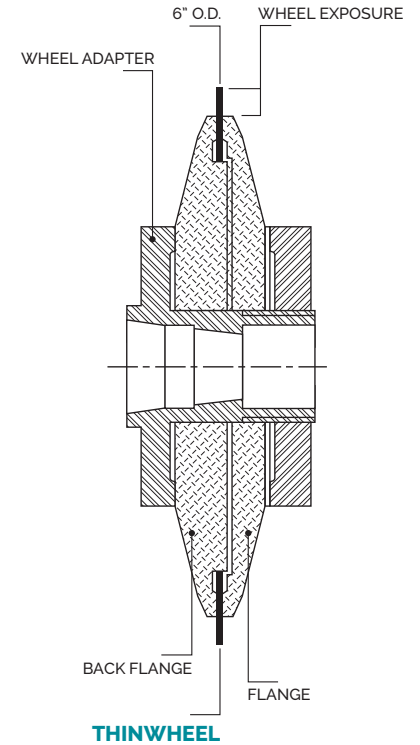

OUTSIDE DIAMETER: 6" INSIDE DIAMETER: 4.5"

➤ **Maximum grit size for the 1A8 Metal Bond wheels is 325/400 mesh or finer.**
 ROUGHER GRIT SIZES MAY BE AVAILABLE UPON REQUEST, BUT THE THICKNESS TOLERANCE MAY VARY AS A RESULT.

Thinwheels available in thickness from .015"-.250" in increments of .001" or a fraction thereof.

3 PIECE MINIMUM ORDER

SUPERABRASIVE SOLID TO HOLE

WHEEL THICKNESS	THICKNESS TOLERANCE	DIAMOND
.015"-.025"	+0/-0.0006"	\$ 223.00
.026"-.050"	+0/-0.0006"	\$ 275.00
.051"-.075"	+0/-0.0006"	\$ 323.00
.076"-.100"	+0/-0.0006"	\$ 363.00
.101"-.125"	+0/-0.0006"	\$ 399.00
.126"-.150"	+0/-0.0006"	\$ 427.00
.151"-.175"	+0/-0.0006"	\$ 456.00
.176"-.200"	+0/-0.0006"	\$ 475.00
.201"-.225"	+0/-0.0006"	\$ 491.00
.226"-.250"	+0/-0.0006"	\$ 499.00

1A8 FLANGES FOR 6" THINWHEEL

A special Diacut flange must be used with the 6" Thinwheel.

PART NO.	DIAMETER	WHEEL EXPOSURE	PRICE
F1A8-675	5.75"	.125"	\$135
F1A8-660	5.60"	.200"	\$132
F1A8-645	5.45"	.275"	\$130
F1A8-630	5.30"	.350"	\$128
F1A8-615	5.15"	.425"	\$125
F1A8-600	5.00"	.500"	\$123
FS600	Complete set of flanges		\$729

Flange thickness for 6" Thinwheel is .700"
 Standard hole size for all flanges is 1.25"
 Special hole size- add \$10
WHEEL EXPOSURE NOT TO EXCEED 15 TIMES THE THICKNESS OF THE BLADE

WHEEL ADAPTERS

Keep grinding wheels mounted for longer wheel life and less dressing time.



WA130-LH Wheel adapter O.D. 3" \$235

PRICES SUBJECT TO CHANGE WITHOUT NOTICE.
 PRICES EFFECTIVE SEPT. 2024
 VISA/MASTERCARD ACCEPTED



P.O. Box 217, 773 Hwy. 105, Palmer Lake, CO 80133
 phone: **719-481-4205** fax: 719-488-0872
 email: **sales@diacut.com** web: www.diacut.com



7" DIAMETER SERIES

METAL BOND Diamond
 Slotting • Slicing • Dicing • Cut-off

OUTSIDE DIAMETER: 7" INSIDE DIAMETER: 5.5"

➤ **Maximum grit size for the 1A8 Metal Bond wheels is 325/400 mesh or finer.**
 ROUGHER GRIT SIZES MAY BE AVAILABLE UPON REQUEST,
 BUT THE THICKNESS TOLERANCE MAY VARY AS A RESULT.

Thinwheels available in thickness from .020"-.250"
 in increments of .001" or a fraction thereof.

3 PIECE MINIMUM ORDER

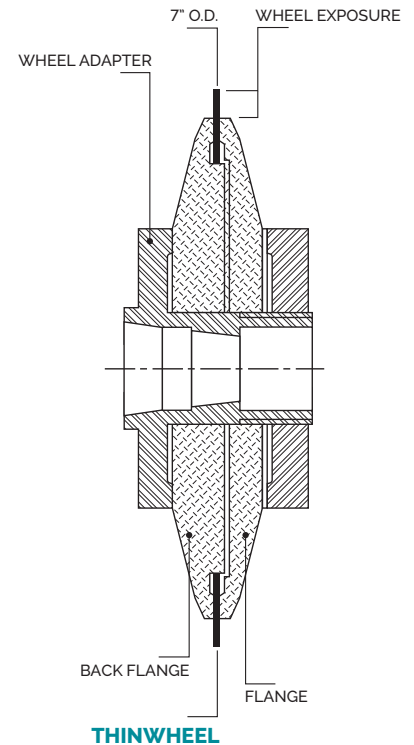

SUPERABRASIVE SOLID TO HOLE

WHEEL THICKNESS	THICKNESS TOLERANCE	DIAMOND
.020"-.025"	+0/-0.0006"	\$ 251.00
.026"-.050"	+0/-0.0006"	\$ 314.00
.051"-.075"	+0/-0.0006"	\$ 368.00
.076"-.100"	+0/-0.0006"	\$ 417.00
.101"-.125"	+0/-0.0006"	\$ 459.00
.126"-.150"	+0/-0.0006"	\$ 495.00
.151"-.175"	+0/-0.0006"	\$ 524.00
.176"-.200"	+0/-0.0006"	\$ 547.00
.201"-.225"	+0/-0.0006"	\$ 565.00
.226"-.250"	+0/-0.0006"	\$ 574.00

1A8 FLANGES FOR 7" THINWHEEL

A special Diacut flange must be used with the 7" Thinwheel.

PART NO.	DIAMETER	WHEEL EXPOSURE	PRICE
F1A8-775	6.75"	.125"	\$168
F1A8-760	6.60"	.200"	\$164
F1A8-745	6.45"	.275"	\$161
F1A8-730	6.30"	.350"	\$158
F1A8-715	6.15"	.425"	\$154
F1A8-700	6.00"	.500"	\$149
FS700	Complete set of flanges		\$890

Flange thickness for 7" Thinwheel is .750"
 Standard hole size for all flanges is 1.25"
 Special hole size- add \$10

WHEEL EXPOSURE NOT TO EXCEED 15 TIMES THE THICKNESS OF THE BLADE

WHEEL ADAPTERS

Keep grinding wheels mounted for longer wheel life and less dressing time.



WA130-LH Wheel adapter O.D. 3" \$235

PRICES SUBJECT TO CHANGE WITHOUT NOTICE.
 PRICES EFFECTIVE SEPT. 2024
 VISA/MASTERCARD ACCEPTED